

**Features**

- Input Voltage: 3.6V to 23V
- Output Voltage: 0.8V to  $V_{CC}$
- Duty Ratio: 0% to 100% PWM Control
- Oscillation Frequency: 300kHz typ.
- Current Limit, Enable Function
- Thermal Shutdown Function
- Built-in Internal SW P-Channel MOS
- SOP-8L Pb-Free Package
- SOP-8L: Available in "Green" Molding Compound (No Br, Sb)
- Lead Free Finish/RoHS Compliant for Lead Free and "Green" Products (Note 1)

**General Description**

AP1520 consists of step-down switching regulator with PWM control. These devices include a reference voltage source, oscillation circuit, error amplifier and internal PMOS.

AP1520 provides low-ripple power, high efficiency and excellent transient characteristics. The PWM control circuit is able to vary the duty ratio linearly from 0 up to 100%. This converter also contains an error amplifier circuit. An enable function, an over current protection and a short circuit protection are built inside, and when OCP or SCP happens, the operation frequency will be reduced from 300kHz to 30kHz. Also, an internal compensation block is built in to minimum external component count.

With the addition of an internal P-channel Power MOS, a coil, capacitors, and a diode connected externally, these ICs can function as step-down switching regulators. They serve as ideal power supply units for portable devices when coupled with the SOP- 8L package, providing such outstanding features as low current consumption. Since this converter can accommodate an input voltage up to 23V, it is also suitable for the operation via an AC adapter.

**Applications**

- PC Motherboard
- LCD Monitor
- Graphic Card
- DVD-Video Player
- Telecom Equipment
- ADSL Modem
- Printer and other Peripheral Equipment
- Microprocessor Core Supply
- Networking Power Supply

**Ordering Information**

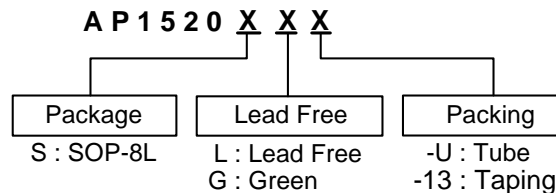

Note: 1. RoHS revision 13.2.2003. Glass and High Temperature Solder Exemptions Applied, see *EU Directive Annex Notes 5 and 7*.

Device	Package Code	Packaging (Note 2)	Tube		13" Tape and Reel	
			Quantity	Part Number Suffix	Quantity	Part Number Suffix
AP1520S	S	SOP-8L	100	-U	2500/Tape & Reel	-13

Note: 2. Pad layout as shown on Diodes Inc. suggested pad layout document AP02001, which can be found on our website at <http://www.diodes.com/datasheets/ap02001.pdf>.

**Pin Assignments**

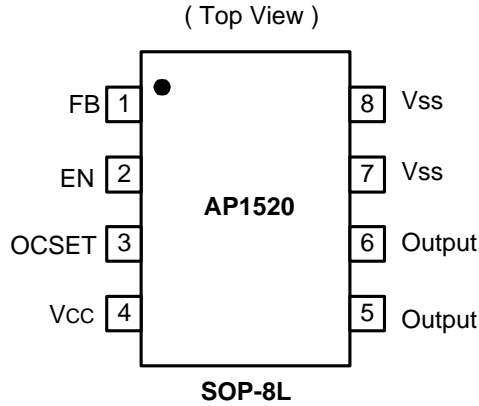

**Pin Descriptions**

Pin Name	Pin No.	Description
FB	1	Feedback pin
EN	2	Enable Input pin H: Normal operation (Step-down operation) L: Step-down operation stopped (All circuits deactivated)
OCSET	3	Add an external resistor to set max output current
V <sub>CC</sub>	4	IC power supply pin
Output	5, 6	Switch Pin. Connect external inductor/diode here. Minimize trace area at this pin to reduce EMI
V <sub>SS</sub>	7, 8	GND Pin

**Block Diagram**

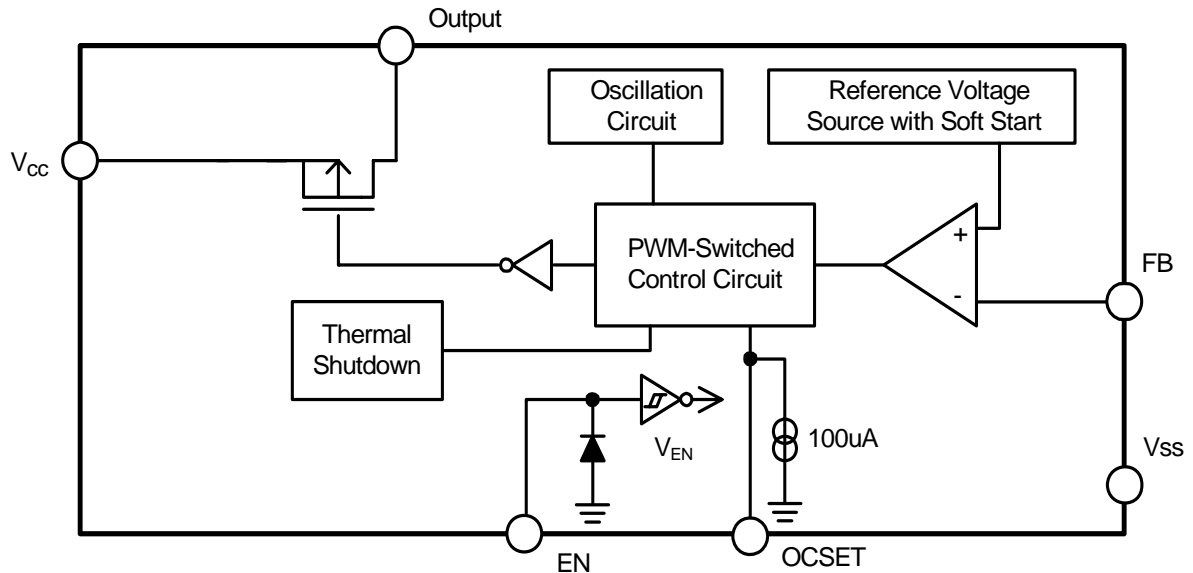

---

**Absolute Maximum Ratings**

---

Symbol	Parameter	Rating	Unit
$V_{CC}$	V <sub>CC</sub> Pin Voltage	$V_{SS} - 0.3$ to $V_{SS} + 25$	V
$V_{FB}$	Feedback Pin Voltage	$V_{SS} - 0.3$ to $V_{CC}$	V
$V_{EN}$	EN Pin Voltage	$V_{SS} - 0.3$ to $V_{IN} + 0.3$	V
$V_{OUT}$	Switch Pin Voltage	$V_{SS} - 0.3$ to $V_{IN} + 0.3$	V
$P_D$	Power Dissipation	Internally limited	mW
$T_{OP}$	Operating Junction Temperature Range	-20 to +125	°C
$T_{ST}$	Storage Temperature Range	-65 to +150	°C

Caution: The absolute maximum ratings are rated values exceeding which the product could suffer physical damage. These values must therefore not be exceeded under any conditions.

---

**Recommended Operating Conditions**

---

Symbol	Parameter	Min	Max	Unit
$V_{IN}$	Input Voltage	4	23	V
$I_{OUT}$	Output Current	0	1.8	A
$T_A$	Operating Ambient Temperature	-25	85	°C

**Electrical Characteristics** (  $V_{IN} = 12V$ ,  $T_a = 25^\circ C$ , unless otherwise specified )

Symbol	Parameter	Conditions	Min	Typ.	Max	Unit
$V_{FB}$	Feedback Voltage	$I_{OUT} = 0.1A$	0.784	0.8	0.816	V
$I_{FB}$	Feedback Bias Current	$I_{OUT} = 0.1A$	-	0.1	0.5	$\mu A$
$I_{SW}$	Switch Current	--	2.5	-	-	A
$I_{SHDN}$	Current Consumption During Power off	$V_{EN} = 0V$	-	10	-	$\mu A$
$\frac{\Delta V_{OUT}}{V_{IN}}$	Line Regulation	$V_{IN} = 5V \sim 23V$	-	1	2	%
$\frac{\Delta V_{OUT}}{I_{OUT}}$	Load Regulation	$I_{OUT} = 0.1$ to 2A	-	0.2	0.5	%
$f_{OSC}$	Oscillation Frequency	Measure waveform at SW pin	240	300	360	kHz
$f_{OSC1}$	Frequency of Current Limit or Short Circuit Protect	Measure waveform at SW pin	10	-	-	kHz
$V_{IH}$ $V_{IL}$	EN Pin Input Voltage	Evaluate oscillation at SW pin Evaluate oscillation stop at SW pin	2.0 -	- -	- 0.8	V
$I_{ENH}$ $I_{ENL}$	EN Pin Input Leakage Current	--	- -	20 -10	- -	$\mu A$
$I_{OCSET}$	OCSET Pin Bias Current	--	75	90	105	$\mu A$
$T_{SS}$	Soft-Start Time	--	0.3	1	2	ms
$T_{SHDN}$	Thermal shutdown threshold		-	150	-	$^\circ C$
$T_{HYS}$	Thermal shutdown hysteresis		-	55	-	$^\circ C$
$R_{DSON}$	Internal MOSFET $R_{DSON}$	$V_{IN} = 5V, V_{FB} = 0V$ $V_{IN} = 12V, V_{FB} = 0V$	- -	110 70	150 100	$m\Omega$
EFFI	Efficiency	$V_{IN} = 12V, V_{OUT} = 5V$ $I_{OUT} = 2A$	-	92	-	%
$\theta_{JA}$	Thermal Resistance Junction-to-Ambient	SOP-8L (Note 3)	-	134	-	$^\circ C/W$
$\theta_{JC}$	Thermal Resistance Junction-to-Case	SOP-8L (Note 3)	-	22	-	$^\circ C/W$

Note: 3. Test condition: Device mounted on FR-4 substrate 2oz copper, minimum recommended pad layout, single side.  
For better thermal performance, please arrange larger copper pad of layout for heatsink.

**Typical Application Circuit**

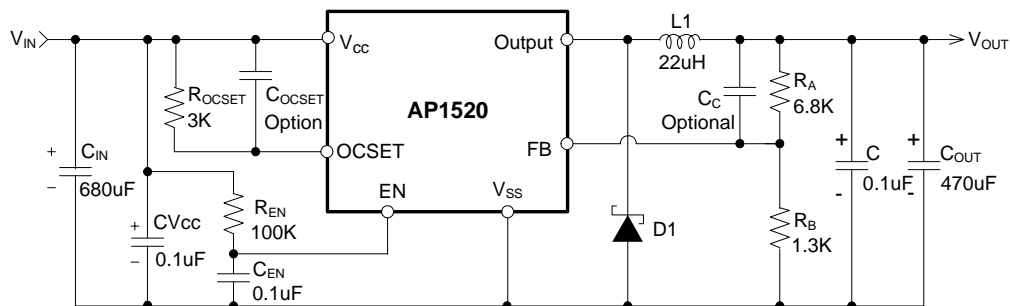

Note:  $V_{OUT} = V_{FB} \times (1 + R_A/R_B)$   
 $R_B = 0.7K \sim 5K \text{ ohm}$

**Typical Performance Characteristics**

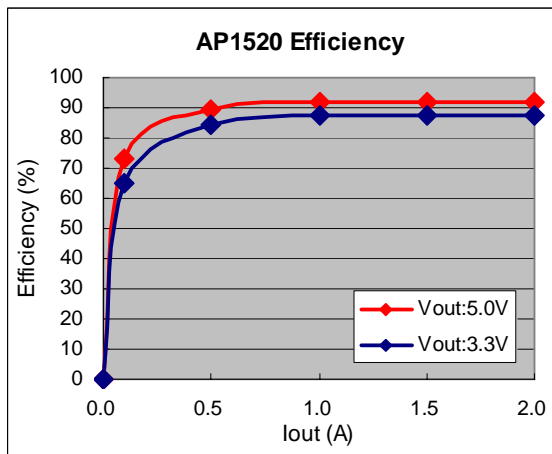
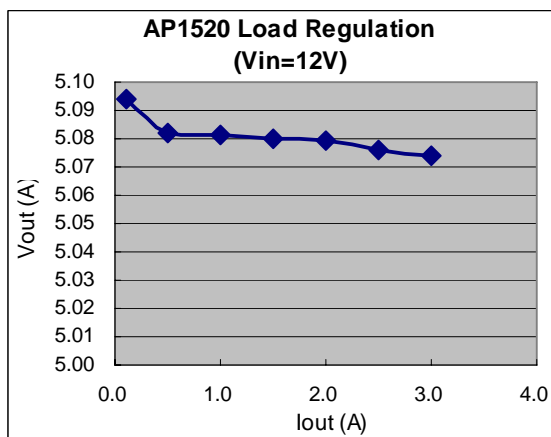
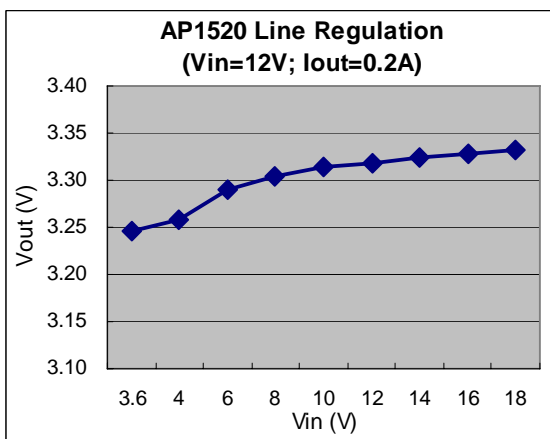
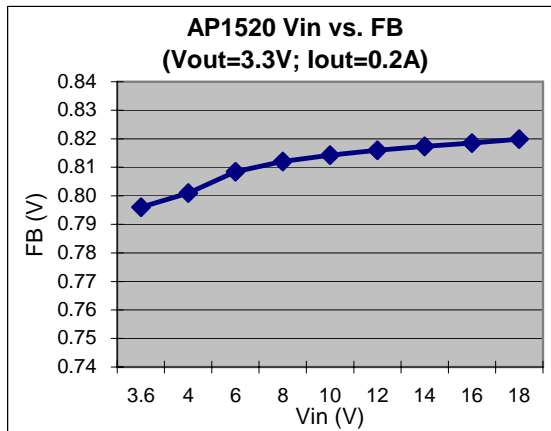
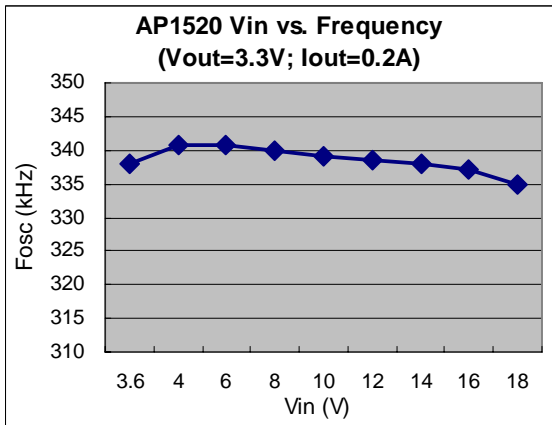

**Typical Performance Characteristics (Continued)**

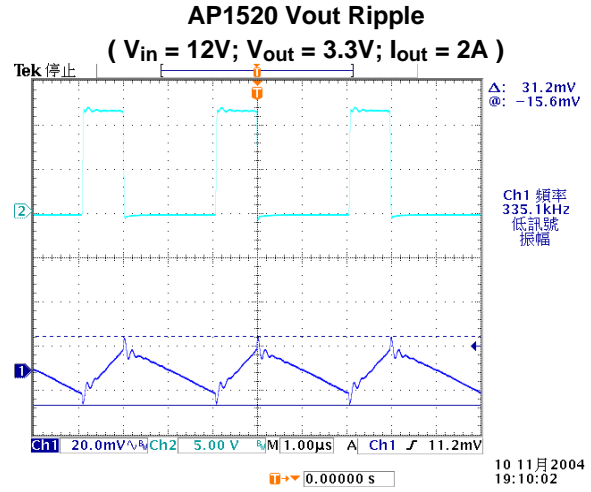
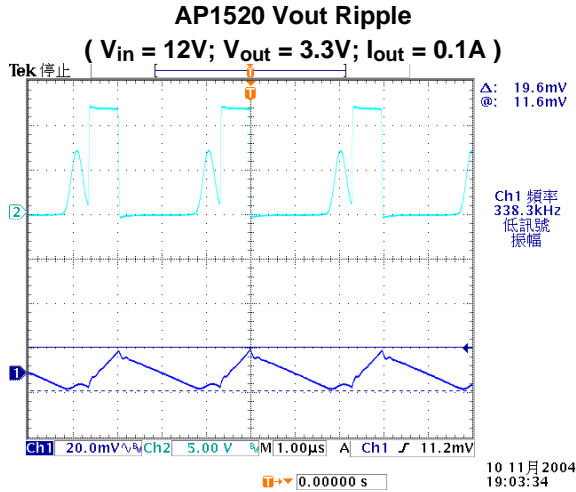

**Test Circuit**

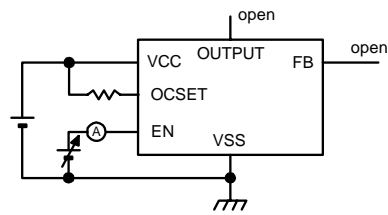

**Enable function test**

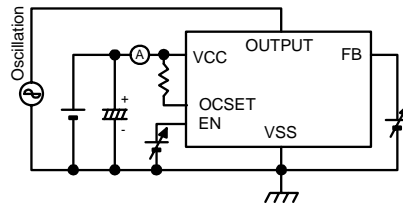

**Feedback function test**

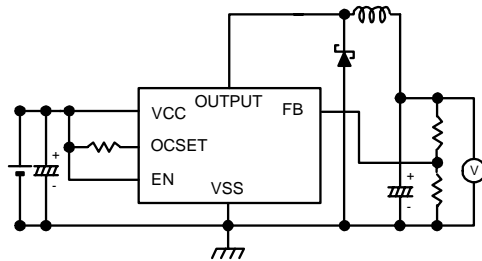

**Operation function test**

## Function Description

### PWM Control

The AP1520 is a DC/DC converter that employs pulse width modulation (PWM) scheme. Its pulse width varies in the range of 0% to 99%, based on the output current loading. The output ripple voltage caused by the PWM high frequency switching can easily be reduced through an output filter. Therefore, this converter provides a low ripple output supply over a broad range of input voltage & output current loading

### Under Voltage Lockout

The under voltage lockout circuit of the AP1520 assures that the high-side MOSFET driver remains in the off state whenever the supply voltage drops below 3.3V. Normal operation resumes once  $V_{CC}$  rises above 3.5V.

### Current Limit Protection

The current limit threshold is set by external resistor  $R_{OCSET}$  connected from  $V_{CC}$  supply to OCSET pin. The internal sink current  $I_{OCSET}$  (90uA typical) across this resistor sets the voltage at OCSET pin. When the PWM voltage is less than the voltage at OCSET, an over-current condition is triggered.

The current limit threshold is given by the following equation:

$$I_{PEAK} \times R_{DS(ON)} = I_{OCSET} \times R_{OCSET}$$

$$I_{PEAK} > I_{OUT(MAX)} + \frac{(\Delta I)}{2}$$

where,

$$\Delta I = \frac{V_{IN} - V_{OUT}}{F_S \times L} \times \frac{V_{OUT}}{V_{IN}}$$

$I_{PEAK}$  is the output peak current;  $R_{DS(ON)}$  is the MOSFET ON resistance.  $F_S$  is the PWM frequency (300KHz typical). Also, the inductor value will affect the ripple current  $\Delta I$ .

The above equation is recommended for input voltage range of 5V to 18V. For input voltage lower than 5V, higher than 18V or ambient temperature over 100°C, high  $R_{OCSET}$  is recommended.

The maximum  $R_{OCSET}$  value should not exceed AP1520 maximum current output.

## Marking Information

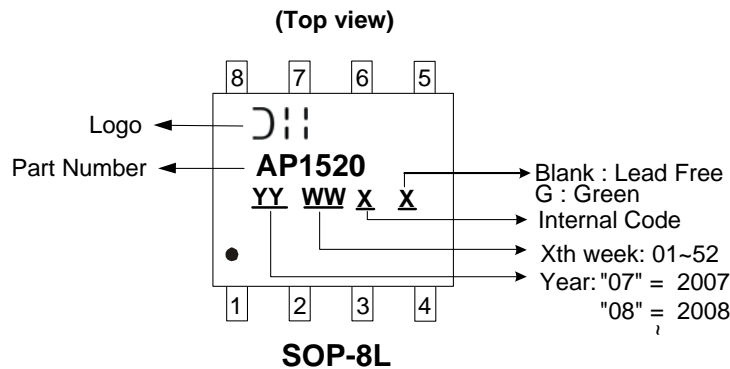

**Package Information ( All Dimensions in mm )**

Package Type: SOP-8L

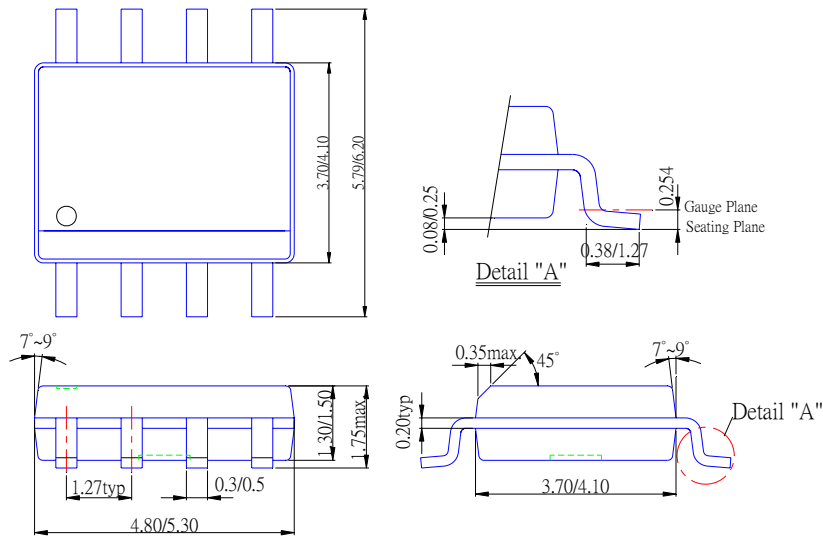

**IMPORTANT NOTICE**

Diodes Incorporated and its subsidiaries reserve the right to make modifications, enhancements, improvements, corrections or other changes without further notice to any product herein. Diodes Incorporated does not assume any liability arising out of the application or use of any product described herein; neither does it convey any license under its patent rights, nor the rights of others. The user of products in such applications shall assume all risks of such use and will agree to hold Diodes Incorporated and all the companies whose products are represented on our website, harmless against all damages.

**LIFE SUPPORT**

Diodes Incorporated products are not authorized for use as critical components in life support devices or systems without the expressed written approval of the President of Diodes Incorporated.